



## MQ 212

### Tailor made for retail and public environments.

With the MQ 212 MultiQ have taken custom made monitor solutions for retail and public environments one step further. The new product offers a solid, stable and very flexible display screen combined in a compact and elegant design.

Metal housing and protective glass gives MQ212 a unique durability even in the most demanding environments.



MQ212 is a 12" LCD-screen

#### Durability

Of course we have kept all the winning features of the earlier product range, such as: metal housing instead of plastic and glass shield to protect the sensitive screen. MQ212 is prepared for Kensington lock. Can also be mounted on to the surface. In MQ212 MultiQ have combined many years of experience of retail, public environments and demands from our customers. The result is a monitor that answers very well to the challenges of retail/ public environments.

#### Functionality

MQ 212 offers a number of special features:

- Integrated card reader
- Enhanced stability despite smaller footprint.
- Power-USB.
- Enhanced tilting angles.
- Integrated cable management; concealed cables with the option of running the cables forwards, backwards and downwards under the table.
- Loudspeakers.
- Medically approved as an option.

#### Custom Design

MQ212 is a flexible platform with unique possibilities for customisation: optional chassis colour, logo in print or relief, card reader, loudspeakers etc. Option of control buttons either front or back. A welcome addition is the option of ordering monitors with zero brightness.

#### Ergonomics

MQ 212 offers several possibilities to improve the ergonomics. The monitor can be ordered with antireflective glass and different touch alternatives. Great tilting angles (possibility to work standing up) and the PURETECH® technique, patented by MultiQ, further improves the ergonomics. PURETECH® reduces the electrical fields to a minimum.



**multiQ**  
Custom design flat monitors



## Technical specifications MQ212

LCD panel type	12.1" LCD TFT
Active display area	246,0 mm (H) x 184,1 mm (V)
Resolution	SVGA, 800x600 max.
Brightness	400 cd/m <sup>2</sup> Typical
Contrast ratio	500:1 Typical
Viewing angle	H:-70°~70° max V:-60°~50° max
LCD monitor colour	262.144 colours
Response time	35 ms nom. (Tr+Tf)
Pixel dimension	0,3075 (H) x 0,3075 (V)
OSD control	Autoset, Brightness, Contrast, Colour, Position, Image, Miscellaneous.
AC/DC adapter	Input: AC 100~240 V, 50~60Hz Output: +12 V DC, 3.3 A
Power consumption	23W Typical
Input signal	Video: Analog 0,7 Vp-p. 75 ohm Sync.: TTL Level, Positive/Negative, Separate sync
Input connector	15 Pin D-sub
Power management	VESA DPMS Compatible Energy Star
Plug & play	DDC2B
Regulations	Safety: UL/Tüv-GS EMI: CE/FCC ISO 13406-2 Medical: EN60601 (option)
Dimensions	Stand: 283 (H)x299 (B) x 129 (D) mm VESA: 250 (H) x 299 (B) x 49 (D) mm
Tilt	With stand: +70°, -0°
Weight (Net)	With stand: 4,3 kg With VESA: 3,3 kg
Temperature	Operation: 0-40°C
Transport & Storage	Ambient Temp: -10 ~60°C Humidity Range: 10~100%
Accessories	AC/DC adapter, power cord, VGA cable. Medical: ground wire Touch: Serial or USB cable
Warranty	3 years SendIT

## Options MQ212

Elo Resistive touch (AccuTouch)  
Elo IR touch (Carroll Touch)  
3M/MicroTouch Capacitive touch  
Different mounting units like VESA, Stand, POS-POLE etc  
Power USB Hub

R1B

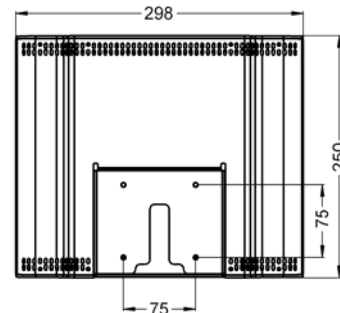
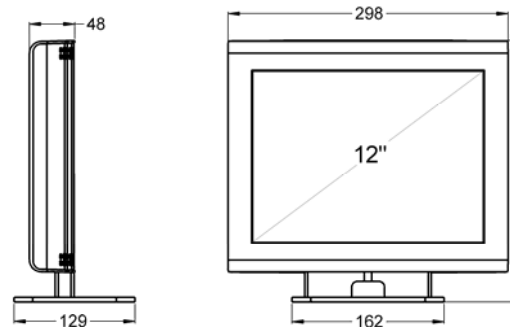

Technical specifications are subject to change without prior notice.



RoHS Compliant 2002/95/EG

## MultiQ Accessories

To maximise the flexibility of your MultiQ monitor we offer a wide range of accessories. You can find them at [www.multiQ.com](http://www.multiQ.com)

**MultiQ Products AB**  
Ridbanegatan 4  
SE-213 77 Malmö  
Tel +46 40 14 35 00  
Fax +46 40 14 35 01  
[www.multiQ.se](http://www.multiQ.se)

**MultiQ AS**  
Brobekkveien 80, Bygg 5  
P.O.Box 352, Økern  
N-0513 Oslo  
Tel +47 2306 7700  
Fax +47 2306 7701  
[www.multiQ.no](http://www.multiQ.no)

**MultiQ Products AB**  
Vertriebsbüro  
Schlachte 39/40  
D-28195 Bremen  
Tel: +49 421 1769 275  
Fax: +49 421 1769 259  
[www.multiQ.de](http://www.multiQ.de)

**MultiQ UK**  
Host Europe House  
Kendal Avenue  
London W3 OXA UK  
Phone +44 208 896 8373  
Fax +44 208896 2325  
[www.multiQ.com](http://www.multiQ.com)

**multiQ**  
Custom design flat monitors